

# PIAF 810

Mast-style boom lift on tracks



[www.atnpiaf.com](http://www.atnpiaf.com)



Preserving fragile floors



Operating on any ground

# PIAF 810

## ADVANTAGES

- Efficiency thanks to the 2 x 110° rotation of the top.
- Designed for any indoor or outdoor job site.
- Smooth operating thanks to the hydraulic joystick.
- Easy to operate.
- Zero turning radius.
- Preserving fragile floors.
- Designed and manufactured for heavy-duty use.

	810
Working height	8,10 m (26 ft. 6,91 in.)
Platform height	6,10 m (20 ft. 0,16 in.)
Horizontal reach	3,00 m (9 ft. 10,11 in.)
Lift capacity	200 kg (441 lbs.)
Turntable rotation	2 x 110°
<b>A</b> Platform width	0,90 m (2 ft. 9,5 in.)
<b>B</b> Platform length	0,80 m (2 ft. 6,2 in.)
<b>C</b> Length - stowed	2,58 m (8 ft. 5,58 in.)
<b>D</b> Trackbase	1,20 m (3 ft. 11,24 in.)
<b>E</b> Width	1,20 m (3 ft. 11,24 in.)
<b>F</b> Height - stowed	1,98 m (6 ft. 6,49 in.)
Turning radius	zero

Gradeability	30%
Maximum tilt value	5°
Drive speed - stowed	1,8 km/h (1,12 mph)
Drive speed - raised	0,8 km/h (0,50 mph)
Weight	2200 kg (4851 lbs)
Max.ground bearing pressure	0,5 kg / cm <sup>2</sup> (7 psi / in. <sup>2</sup> )

## STANDARD FEATURES

- Non-marking rubber tracks.
- Progressive hydraulic joystick transmission.
- Driving operated by a hydraulic joystick.
- 560 Ah centralized battery filling system.
- 50 A battery charger.
- 2 drive speeds.
- Lifting facilities.
- Emergency hand-pump.
- Battery indicator with 80% discharge cut-off.
- Tilt indicator with buzzer.
- Overload sensor.
- System preventing from tipping over.
- Hour meter.
- Strong large size platform.

## OPTIONS

- Air line to platform.
- 220V AC power to platform.
- Automatic power cut-off if tilt value >5°.
- Special paint colour(s).



This product complies with European regulations in force(EN 280).  
Due to our constant improvement policy,  
ATN reserves the right to make any modifications  
without any prior notice.

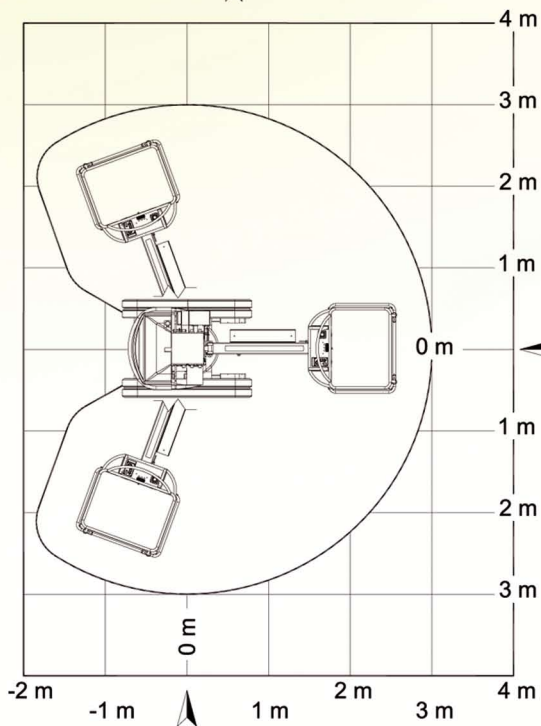
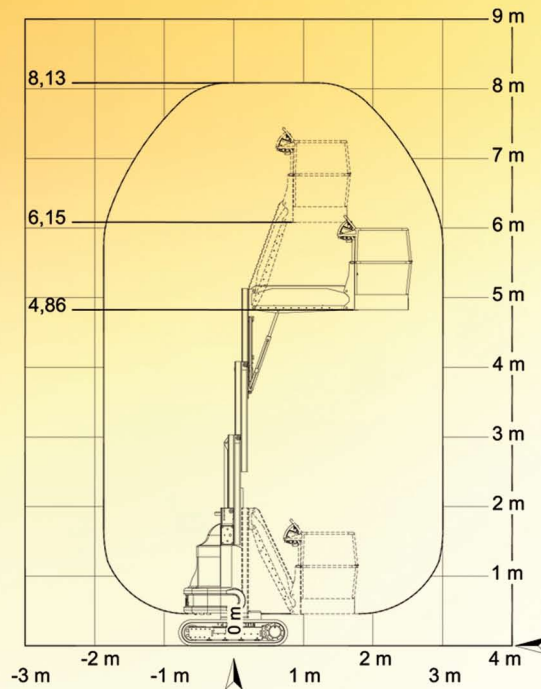
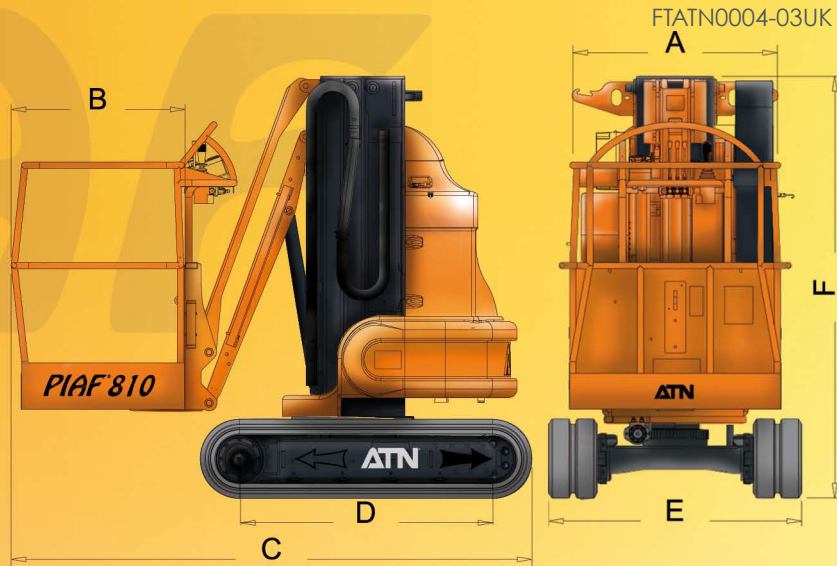

www.atnpiaf.com

2 rue du Pont de Garonne - 47400 Tonneins - FRANCE  
Tel : + 33 553 883 723 - Fax : + 33 553 880 107  
e-mail : contact@atnpiaf.com